

## **USER MANUAL**

**Product:** ECO POWER PACK 60K

**Model:** 230V, 16A/32A/63A, Single/3 Phase



QUAYSIDE INDUSTRIAL PARK  
BATES ROAD  
MALDON, ESSEX  
CM9 5FA



## WARNING



**This product generates voltages which can cause serious injury or death if proper precautions are not taken, or if used improperly.**

**This product should only be used by competent persons who have read and understood this user manual, and all instructions regarding its use and safety should be observed.**



## WARNING

**IMPORTANT: The DC connection (Anderson connectors on the unit) should not be connected unless the key switch is already in the "ON" Position.**

**If the DC supply is already connected when the key switch is turned to "ON", the in-rush current may trip the batteries, which in turn will disable the entire system. It may not recover without LGP Service Engineer intervention.**

Keep this user's manual handy so that you can refer to it at any time. This user's manual is considered a permanent part of the ECO Power Pack 60k and should remain with the ECO Power Pack 60k if resold.

The information and specifications included in this publication were in effect at the time of approval for printing. Light Green Power Ltd. reserves the right, however, to discontinue or change specifications or design at any time without notice and without incurring any obligation whatever.

### Revision history

Version	Date
A	20 <sup>th</sup> November 2023
B	3 <sup>rd</sup> April 2024

CONTENTS

1	INTRODUCTION.....	5
1.1	Instructions for Use.....	5
1.2	Identification of Product .....	5
1.3	Modifications to Product .....	5
1.4	Product Compliance and Conformity .....	5
1.6	Specification .....	7
2	Safety Information .....	8
2.1	General.....	8
2.1.1	Operator responsibility .....	8
2.1.2	Electric shock hazards .....	8
3	Transportation .....	9
3.1	ECO Power Pack 60k.....	9
3.2	Care during transport.....	10
3.3	Safe handling.....	10
3.3.1	Manual Handling .....	10
4	Site Deployment.....	11
4.1	Site Conditions .....	11
4.1.1	Safety Equipment.....	11
4.1.2	Initial Machine Position .....	11
4.1.3	Earthing Point.....	11
5	Controls and features.....	12
5.1	Control panel components.....	12
5.1.1	Power switch .....	12
5.2	Features .....	12
5.2.1	AC Connections .....	12
5.2.2	DC Outlets .....	13
5.2.3	AC charging input.....	14
6	Before operation.....	15
6.1	ECO Power Pack 60k condition.....	15
6.1.1	Environmental conditions .....	15
6.1.2	Breakers.....	15
7	Operation .....	17
7.1	Safe operating precautions.....	17
7.2	Turning on the Machine .....	17
7.3	User Screen Interpretation.....	17
7.4	Checking the battery level .....	18
7.5	Charging the battery .....	18
7.6	DC Operation.....	19
7.7	AC operation.....	19

---

7.7.1	AC output protection .....	21
7.8	Operating time .....	23
7.8.1	Capacity .....	23
7.8.2	Expected AC operating time .....	23
7.8.3	Strategies for increasing operating time .....	23
8	Service and maintenance .....	24
9	Storage .....	25
9.1	Before storage .....	25
9.2	Storage precautions .....	25
9.3	Removal from storage .....	25
10	MAINTENANCE .....	26
10.1	Cleaning .....	26
10.2	Inspection .....	26
10.2.1	Decals and Labels .....	26
11	Options .....	27
12	Troubleshooting .....	27

# 1 INTRODUCTION

Light Green Power Ltd (LGP) ECO Power Pack 60k is an eco-friendly, robust, and compact mobile power supply. The ECO Power Pack 60k contains 60kWh of battery capacity to provide rechargeable power in remote locations. The device can be charged with mains electricity or combined with other LGP products such as Hydrogen Fuel Cells to recharge. Multiple ECO Power Pack 60ks can be linked together to provide increased capacity.

The ECO Power Pack 60k is suitable for outdoor and indoor use. The rugged ECO Power Pack 60k construction also makes it easy to maneuver and deploy.

## 1.1 INSTRUCTIONS FOR USE

This User's Manual is a vital reference source for new users and must be retained. When not in use the manual is stowed in the documentation tube clipped to the machine OR it could be found using a QR code labeled "PP60k manual" on pasted the body of the unit. Make sure that you read the operating instructions carefully before use. With proper care, this product will provide reliable, long-term service.

All information, illustrations and specifications contained in this publication are based on the latest product information available at the time of publication. LGP reserve the right to make changes at any time without notice. Continued improvement and advancement of the design may cause changes to the machine that may not be included in this publication.

PLEASE READ THE OPERATING INSTRUCTIONS CAREFULLY AND UNDERSTAND THEM BEFORE YOU OPERATE THE MACHINE.

## 1.2 IDENTIFICATION OF PRODUCT

This manual may refer to controls and equipment that are not present on your model. It is important that you become familiar with your machine and its equipment and how to operate it properly.

Information about the model and serial number is on the serial number plate on the side of the machine. Always quote the model and serial number in correspondence with your dealer or the manufacturer.

## 1.3 MODIFICATIONS TO PRODUCT

LGP may from time-to-time issue service bulletins. These will keep you up to date as to any improvements or changes that may take place on the complete assembly or component parts.

## 1.4 PRODUCT COMPLIANCE AND CONFORMITY

The ECO Power Pack 60k has been designed and assessed with reference to the relevant UK Regulations:

Electrical Equipment Regulations 2016

EMC Directive 2014/30/EU and UK Electromagnetic Compatibility Regulations 2016

Full details can be found in the technical file which can be obtained from LGP. Each new machine is issued with a warranty certificate and a certificate of conformity, which are sent to the head office of the purchaser. Further copies are available on request.

Website: [www.lightgreenpower.co.uk](http://www.lightgreenpower.co.uk)  
E-mail: [sales@lightgreenpower.co.uk](mailto:sales@lightgreenpower.co.uk)  
Telephone: +44(0)3450 772838Light Green Power Ltd  
Quayside Industrial Park  
Bates Road, Maldon  
Essex CM9 5FA**UK DECLARATION OF CONFORMITY**

Product: ECO Power Pack 60K

Manufacturer: Light Green Power Ltd  
Quayside Industrial Park  
Bates Road  
Maldon  
Essex  
UK  
CM9 5FA

We declare that the above referenced product is in conformity with the following UK regulations:

Electrical Equipment (Safety) Regulations 2016

EN 62368-1:2014\*  
EN IEC 61293:2020

Electromagnetic Compatibility Regulations 2016

*Applied and, as modified, met EMC test standards:***Emissions**

EN 50121-4:2016

- Radiated disturbance - EN 55011:2016 inc A1:2017 & A11:2020

**Immunity\***

EN 50121-4:2016

- Electrostatic discharge - EN 61000-4-2:2009
- Radiated RF interference - EN 61000-4-3:2006 inc A1:2008 & A2:2010
- Fast transient bursts (power outlet) - EN 61000-4-4:2004 inc A1:2010
- Conducted RF field (power outlet) - EN 61000-4-6:2009
- Power frequency magnetic field - EN 61000-4-8:2010
- Pulsed magnetic field - EN 61000-4-9:1993

The Restriction of the Use of Certain Hazardous Substances in Electrical and Electronic Equipment Regulations (RoHS)

*The product and all the components contained within it are in accordance with the restriction of the use of hazardous substances in electrical and electronic equipment.*

Authorised Signature ( 13 / 01 / 2023 )

## 1.6 SPECIFICATION

UKCA plate markings on the ECO Power Pack 60k show that the machine conforms to all applicable directives.

LGP model	ECO Power Pack 60k
Overall length	1200 mm
Overall width	1200mm
Overall height	1300mm
Gross weight	900kg
Lifting positions	4 x hoist points Forklift Pockets
Output voltage	Output voltage: 230 VAC $\pm$ 2% (16A ,32A) 3 $\phi$ 400 VAC (32 A)
Output Frequency	50 Hz $\pm$ 0,1%
Output power (max) (at 25°C) (refer to Table 1.6.1)	15kVA 3 $\phi$ output 5000VA per phase

**Table 1.6.0**

Output Power	Single Phase Output	3 Phase Output
Cont. output power at 25°C (a)	5000 VA	15000 VA
Cont. output power at 25°C	4000 W	12000 W
Cont. output power at 40°C	3700 W	11100 W
Cont. output power at 65°C	3000 W	9000 W
Maximum apparent feed-in power	5000 VA	15000 VA
Peak power	9000 W	27000 W
(a) Non-linear load, crest factor 3:1		

**Table 1.6.1**

## 2 Safety Information

### 2.1 GENERAL

To prevent unexpected and unnecessary down time, report all malfunctions to LGP. Do not operate the machine until corrected. This manual describes general examinations and operations with the safety precautions required for normal operating conditions. It is not a guide however, for other than normal conditions or situations.

Users must be always safety conscious. Be aware of potential operating safety hazards and take the necessary precautions to ensure safe operation of the machine.

This ECO Power Pack 60k is designed for use with electrical equipment that has suitable power requirements. Other uses can result in injury to the operator or damage to the ECO Power Pack 60k and other property. Before using the ECO Power Pack 60k, ensure an adequate risk assessment has been undertaken for the work task and the work environment.

Most injuries or property damage can be prevented if you follow all instructions in this manual and on the ECO Power Pack 60k. The most common hazards are discussed below, along with the best way to protect yourself and others.

#### 2.1.1 Operator responsibility

- Know how to switch off the ECO Power Pack 60k quickly in case of an emergency.
- Understand the use of all controls, output receptacles and connections.
- Be sure that anyone who operates the ECO Power Pack 60k receives proper instruction. Do not let any unqualified or untrained personnel operate the ECO Power Pack 60k.

#### 2.1.2 Electric shock hazards

- The ECO Power Pack 60k produces voltages sufficient to cause serious injury if misused.
- Only use the ECO Power Pack 60k with suitable cable and plug connected equipment, noting the rated power and voltage.
- Only use the ECO Power Pack 60k with equipment, which is well maintained, and do not use with any equipment which is damaged.
- Do not use extension leads longer than 14 metres or splitters with the ECO Power Pack 60k.
- Do not attempt to disassemble the unit except for the maintenance prescribed in this user's manual.
- Do not connect the AC output to the electrical supply of a building.
- Do not attempt to bond the chassis of the ECO Power Pack 60k to earth (via earth spike, permanent structural metalwork, etc), as this can create an electric shock hazard in case of earth faults.
- Do not place the unit in pooled surface water and avoid immersion and direct spraying with water. If the ECO Power Pack 60k has been partially or fully immersed in water, DO NOT USE. Return the ECO Power Pack 60k to your distributor for maintenance.



### 3 Transportation

#### 3.1 ECO POWER PACK 60K



The machine is designed to be lifted by forklift using the pockets provided (highlighted in red in image below, from either side) or using the four lifting/hoist points which are clearly marked on the machine.

When hoisting, all four lifting points must be used. Any less will result in an unsafe, unbalanced load.

Always remain aware of the position of other people around you when you lift the machine.

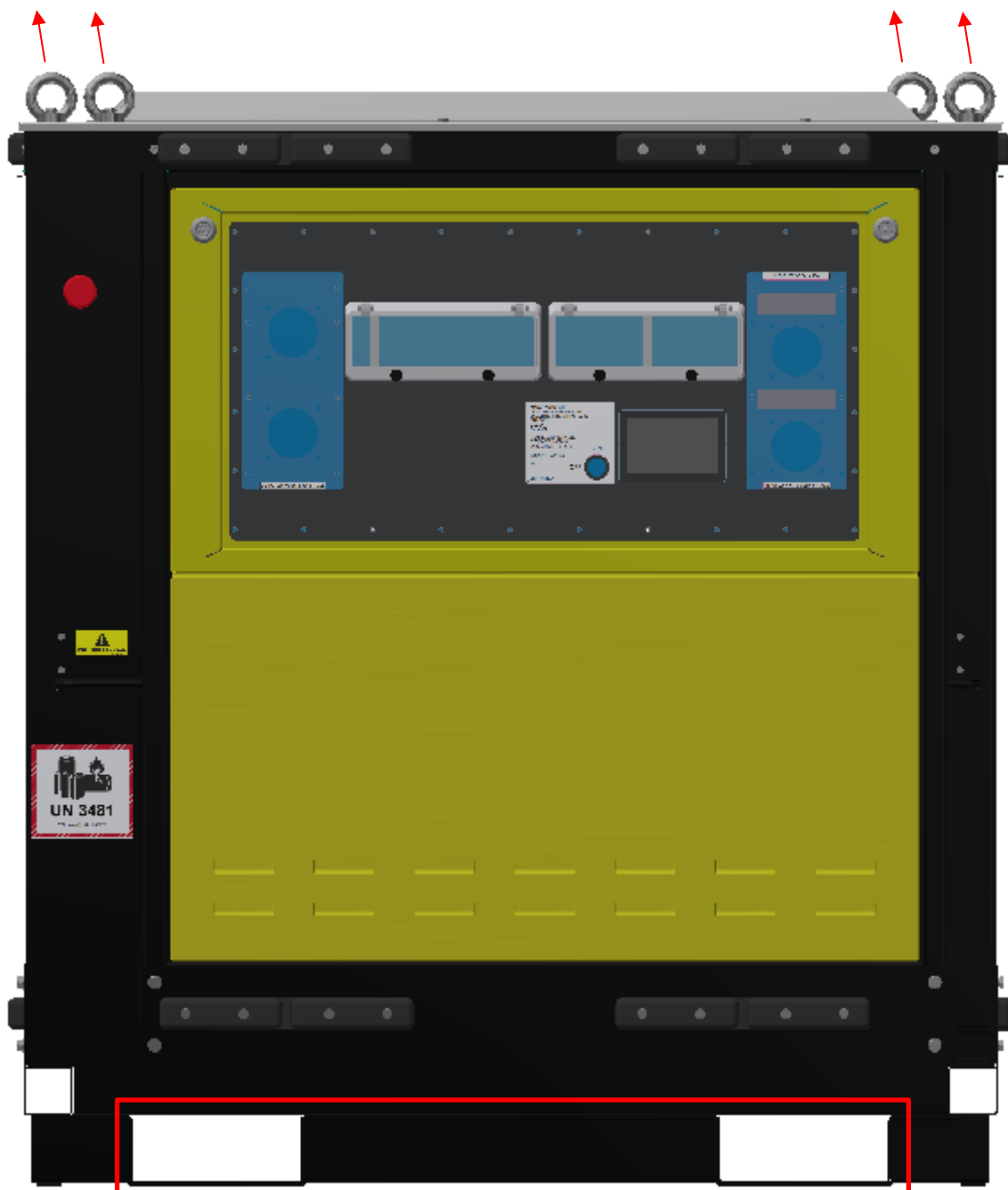

For transportation, strap securely using the pull-down lugs shown below.



Return this manual to the documentation tube for transportation with the machine.

### **3.2 CARE DURING TRANSPORT**

When transporting the ECO Power Pack 60k, observe the following instructions to prevent damage to the ECO Power Pack 60k or other equipment:

- Secure the ECO Power Pack 60k in a stable, level position to avoid damage from tipping or falling.
- Protect the ECO Power Pack 60k from impact during transport (e.g., securing any other equipment being transported).
- Avoid exposing the ECO Power Pack 60k to excessive levels of vibration during transport to avoid mechanical damage to the ECO Power Pack 60k.

### **3.3 SAFE HANDLING**

#### **3.3.1 Manual Handling**

When moving the ECO Power Pack 60k, observe the following instructions to ensure your safety:

- The ECO Power Pack 60k is heavy, and as such it is not recommended to be manually carried by any number of people. If the machine needs to be lifted this should be done by forklift or crane.
- Disconnect all loads and charging inputs from the ECO Power Pack 60k before moving and ensure that the AC output is switched off before carrying.

## 4 Site Deployment

### 4.1 SITE CONDITIONS

#### 4.1.1 Safety Equipment

Know what safety equipment is required and use it. The minimum PPE when you deploy or operate the machine is safety glasses, protective gloves, and safety footwear.

A hard hat, high visibility vest, respirator and earplugs may also be a site requirement.

#### 4.1.2 Initial Machine Position



Make sure the machine is deployed on firm and level ground. Make sure that the area that immediately surrounds the machine is clean, neat, and free of debris.

#### 4.1.3 Earthing Point

An earth point is provided and labelled on the outside of the enclosure for use as required.

## 5 Controls and features

### 5.1 CONTROL PANEL COMPONENTS

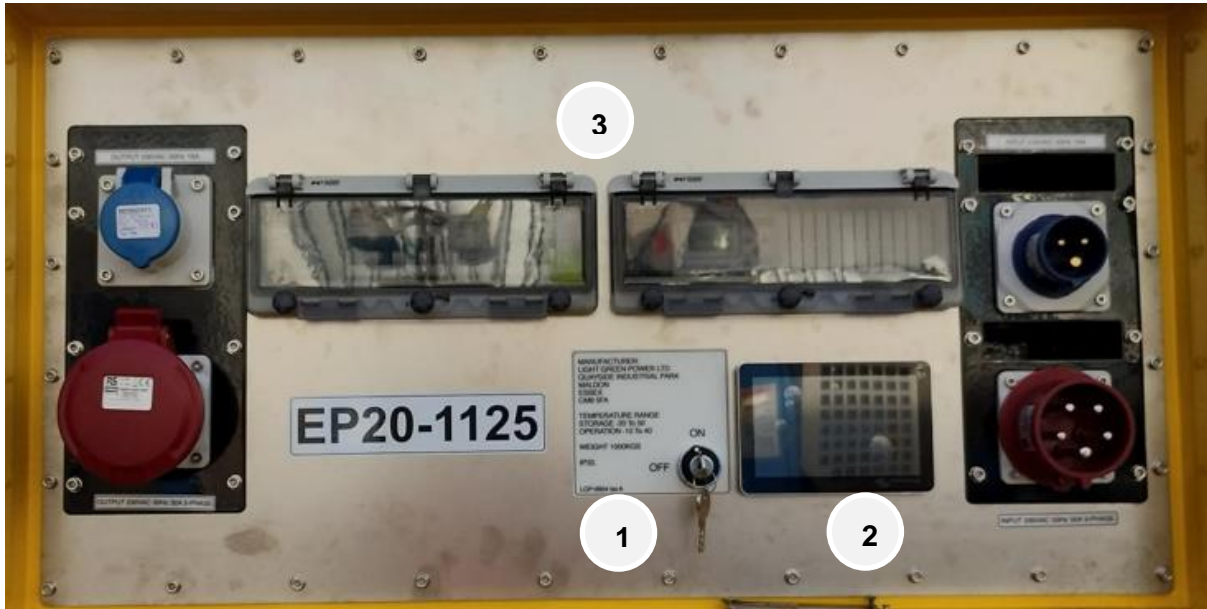

1. Power switch (key)
2. Screen
3. Breaker Boxes

#### 5.1.1 Power switch

The power switch controls the operation of the ECO Power Pack 60k:

- OFF - Stops all operation of the ECO Power Pack 60k, including charging.
- ON - Starts the AC output, allows charging if AC mains cable / solar / hydrogen fuel cell is connected. DC Output will also be enabled.

Note that there may be a delay of a few seconds when the power switch is moved to the 'ON' position, while the ECO Power Pack 60k does its self-tests.

## 5.2 FEATURES

### 5.2.1 AC Connections

The power pack incorporates one 32A three phase outlet, one 32A three phase inlet, three 32A outlets, two 16A outlets, one 16A inlet all suitable for cable and plug connected electrical equipment. The connections are fitted as shown below.



**5.2.2 DC Outlets**

DC outlets are located on the rear of the unit in the form of two SB175 Anderson connectors. Voltage 48-57V, 200Amp Max combined.



**5.2.3 AC charging input****WARNING**

**The ECO Power Pack 60k must be maintained (and stored) in a charged state. A monthly maintenance charge is recommended. A battery pack stored in a discharged state can cause battery cell damage and void manufacturer's warranty. NB: The ECO Power Pack 60k will log all activity and so failure to charge the ECO Power Pack 60k will be stored on product memory.**

The ECO Power Pack 60k incorporates a charging circuit, which facilitates recharging of the unit from using the supplied mains cable. Maximum charging current is limited to 32A. Charging is only possible with the power switch in the 'ON' position. The battery status monitor display on the screen will indicate that charging is taking place and the current state of the battery charge.

**WARNING**

**Do not attempt to use any charger or power supply to charge the ECO Power Pack 60k, other than that supplied or recommended by Light Green Power Ltd. Using a different charger could result in serious malfunction and damage to the equipment.**

## 6 Before operation



# WARNING

**IMPORTANT:** The DC connection (Anderson connectors to the rear of the unit) should not be connected unless the key switch is already in the “ON” Position.

If the DC supply is already connected when the key switch is turned to “ON”, the in-rush current may trip the batteries, which in turn will disable the entire system. It may not recover without LGP Service Engineer intervention.

### 6.1 ECO POWER PACK 60K CONDITION

Always inspect the ECO Power Pack 60k before use to make sure that it is in good mechanical condition. Do not attempt to use an ECO Power Pack 60k that is damaged in any way, and do not use the ECO Power Pack 60k with any electrical equipment that is damaged or not functioning correctly.



# WARNING



**Use of a damaged or malfunctioning ECO Power Pack 60k, or use of the ECO Power Pack 60k with damaged or malfunctioning equipment, can result in serious injury or death, or damage to property. Faults and error messages must be reported at the earliest opportunity, warranty issues must be reported within 48 hours. Failure to do so could void manufacturer’s warranty.**

#### 6.1.1 Environmental conditions

The ECO Power Pack 60k should only be used in a suitable environment where the unit is not at risk of damage from the environment. Reasonable judgement of competent persons should be used to determine an appropriate environment, but as a minimum, the following should be observed:

- DO NOT cover the vents on the sides or top of the ECO Power Pack 60k during use.
- DO NOT use the ECO Power Pack 60k in an excessively dusty environment.
- DO NOT use the ECO Power Pack 60k in an ambient air temperature of above 40°C.
- Be aware of water pooling or splashing when using the pack in wet and rainy conditions (rated to IP23)
- DO NOT allow the ECO Power Pack 60k to be exposed to excessive mechanical vibration, impact, or static force.



# WARNING



**Use of the ECO Power Pack 60k in an environment which is unsuitable can lead to equipment malfunction, which can result in serious injury or death, or damage to property.**

#### 6.1.2 Breakers

Breakers/trips should be in the following positions:

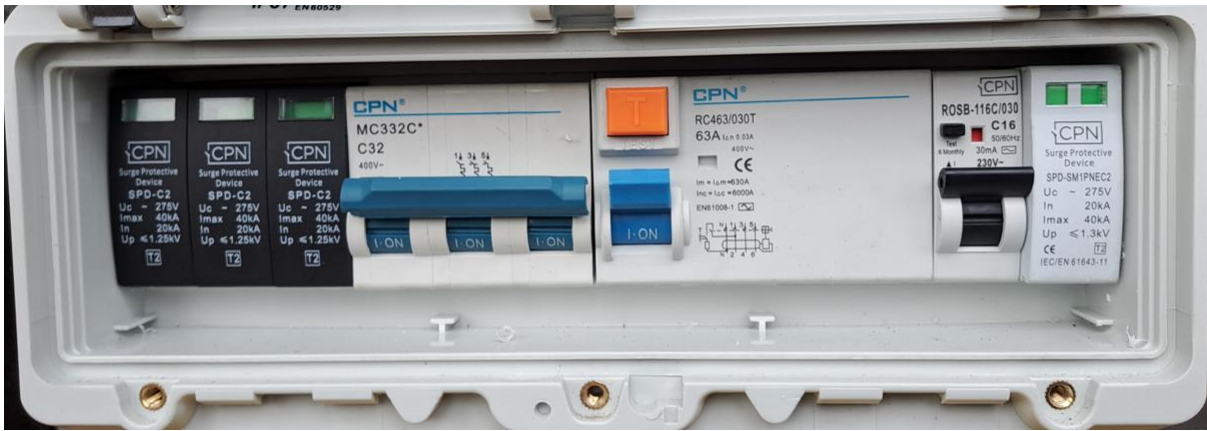



## Operation

### 6.2 SAFE OPERATING PRECAUTIONS

Before connecting an AC appliance or power cord to the generator:

- Use grounded 3-pole extension cords, tools, and appliances, or double-insulated tools and appliances.
- Inspect cords and plugs and replace if damaged.
- Make sure that the appliance is in good working order. Faulty appliances or power cords can create a potential for electric shock.
- Make sure the electrical rating of the tool or appliance does not exceed the specified phase of the PP60K. Never exceed the maximum power rating of the PP60K.

### 6.3 TURNING ON THE MACHINE

To turn on the machine, Follow the following flow chart.

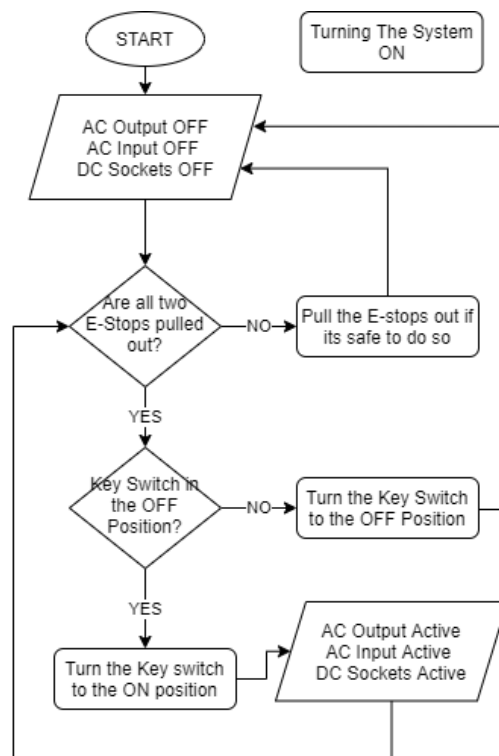

this will activate the following activities:

- Allow charging via mains, hydrogen fuel cell or solar where connections have been made and sources are turned on.
- Allow power out to the AC/DC loads where connection have been made and loads are turned on.

### 6.4 USER SCREEN INTERPRETATION

The user screen is designed to give the user information about the PP60K system. The screen turns on when the key switch to turned to the 'on' position. It will go to standby after some time and can be woken up by touching the screen. The dashboard displayed below is all a standard user will need, however full instructions as to the using of the screen and Cerbo system are provided on the Victron website. Most of the advanced features will be password protected for LGP personnel only.

The dashboard shown below will give the following information:

- Whether the inverter is on or off, it will be off until required to charge the batteries or supply power to a load.
- Whether there is AC power supplying input to the inverter to charge the batteries or directly to a load
- Whether there is an AC load to demand power from the inverter, which phase is being used and the power draw.
- The state or charge of the batteries and the power and current drawn
- Whether there is a DC load and the power draw
- Whether there is DC power supplying input to the inverter
- Whether there is a Solar supply to the inverters

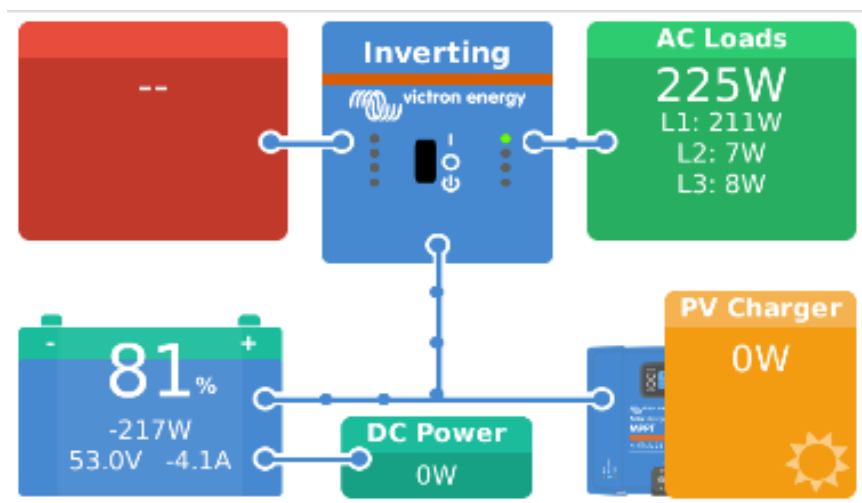

## 6.5 CHECKING THE BATTERY LEVEL

Use the battery indicator as described below. If the battery level is low, do not use the ECO Power Pack 60k, but charge from the supplied DC source for at least two hours.

1. If the ECO Power Pack 60k is already in use, leave the key switch in the “ON” position. If the ECO Power Pack 60k is currently turned “OFF”, change the key switch to the ‘on’ position.
2. The screen will illuminate, and the battery conditions can be monitored.

## 6.6 CHARGING THE BATTERY

The process to charge the internal battery is as follows:

1. Switch the supply off at the mains.
2. Connect the supplied cable to the AC inlet on the front panel.
3. Switch on the mains supply.
4. If the ECO Power Pack 60k is already in use, leave the key switch in the “ON” position. If the ECO Power Pack 60k is currently turned “OFF”, change the key switch to the ‘on’ position.
5. Charging should take about 8 hours, depending on the initial state of charge. During charging, the screen will display the current state of charge (in the blue battery % indicator at the bottom left).
6. When you have finished charging, disconnect the cable before moving the ECO Power Pack 60k.
7. Battery charging can also be achieved by auxiliary input such as solar or hydrogen fuel cell. The correct connections need to be made taking note of instructions given by the auxiliary product used manual. Then instructions 3. to 6. should be applied as above.

*If charging does not start:*



- *Make sure that the front panel switch is in the ‘on’ position.*
- *Make sure that the cable is connected securely, and the mains is switched on.*

- *If the battery is too low, the inverter may not turn on, which will not allow the batteries to charge. Never allow the ECO Power Pack 60k Battery State of Charge to drop below*



## WARNING

**IMPORTANT: The DC connection (Anderson connectors to the rear of the unit) should not be connected unless the key switch is already in the “ON” Position.**

**If the DC supply is already connected when the key switch is turned to “ON”, the in-rush current may trip the batteries, which in turn will disable the entire system. It may not recover without LGP Service Engineer intervention.**

### 6.7 DC OPERATION

The AC output of the ECO Power Pack 60k is controlled via the key switch (see ‘controls’). DC power output is always on when the key switch is turned to the ‘on’ position.

Before connecting an appliance or power cord to the ECO Power Pack 60k:

- Make sure that it is in good working order. A faulty appliance or power cord can create a potential for electrical shock.
- If an appliance begins to operate abnormally, becomes sluggish, or stops suddenly, turn it off immediately. Disconnect the appliance and determine whether the problem is the appliance or the rated load capacity of the ECO Power Pack 60k has been exceeded.
- Make sure that the combined electrical rating of the tools or appliances do not exceed that of the ECO Power Pack 60k. Never exceed the maximum power rating of the ECO Power Pack 60k which is 5000W maximum power (intermittent use) and 4000W continuous power at 25°C per phase. The continuous power is reduced to 3700W for above 40 °C.

**Make sure that the appliance or power cord is switched off before connecting to the ECO Power Pack 60k. Switch the DC outlet of the ECO Power Pack 60k on before switching on the appliance or connecting power cord.**

### 6.8 AC OPERATION

The AC output of the ECO Power Pack 60k is controlled via the key switch (see ‘controls’). When the AC power output is on, the screen will display that the inverter is on.

Before connecting an appliance or power cord to the ECO Power Pack 60k:

- Make sure that it is in good working order. A faulty appliance or power cord can create a potential for electrical shock.
- If an appliance begins to operate abnormally, becomes sluggish, or stops suddenly, turn it off immediately. Disconnect the appliance and determine whether the problem is the appliance or the rated load capacity of the ECO Power Pack 60k has been exceeded.
- Make sure that the combined electrical rating of the tools or appliances do not exceed that of the ECO Power Pack 60k. Never exceed the maximum power rating of the ECO Power Pack 60k which is 5000W maximum power (intermittent use) and 4000W continuous power at 25°C per phase. The continuous power is reduced to 3700W for above 40 °C.

**Make sure that the appliance or power cord is switched off before connecting to the ECO Power Pack 60k. Switch the AC outlet of the ECO Power Pack 60k on before switching on the appliance or power cord.**



*Do not exceed the rated power of the ECO Power Pack 60k. Substantial overloading may damage the ECO Power Pack 60k. Marginal overloading may shorten the service life of the ECO Power Pack 60k.*

### 6.8.1 AC output protection

Under certain circumstances, the ECO Power Pack 60k will stop providing AC power to protect itself or the user. Generally, there will be a warning provided before the AC power cuts out. These are detailed below:

Problem	Cause	Solution
No output voltage on AC-out-2, even after waiting.	MultiPlus-II GX in inverter mode	
Multi will not switch over to generator or mains operation.	Circuit breaker or fuse in the AC-in input is open as a result of overload.	Remove overload or short circuit on AC-out-1 or AC-out-2, and reset fuse/breaker.
Inverter operation not initiated when switched on.	The battery voltage is excessively high or too low. No voltage on DC connection.	Ensure that the battery voltage is within the correct range.
'Low battery'	The battery voltage is low.	Charge the battery or check the battery connections.
'Low battery' (Shutdown)	The converter switches off because the battery voltage is too low.	Charge the battery or check the battery connections.
'Overload'	The converter load is higher than the nominal load.	Reduce the load.
'Overload' (Shutdown)	The converter is switched off due to excessively high load.	Reduce the load.
'Over Temperature'	The environmental temperature is high, or the load is too high.	Install the converter in cool and well-ventilated environment, or reduce the load.
'Low Bat V Overload' (Shutdown)	Low battery voltage and excessively high load.	Charge the batteries, disconnect or reduce the load, or install higher capacity batteries. Fit shorter and/or thicker battery cables.
'High DC Ripple'	Ripple voltage on the DC connection exceeds 1,5Vrms.	Check the battery cables and battery connections. Check whether battery capacity is sufficiently high, and increase this if necessary.
'DC Ripple Shutdown'	The inverter is switched off due to an excessively high ripple voltage on the input.	Install batteries with a larger capacity. Fit shorter and/or thicker battery cables, and reset the inverter (switch off, and then on again).
The charger does not operate.	The AC input voltage or frequency is not within the range set.	Ensure that the AC input is between 185VAC and 265VAC, and that the frequency is within the range set (default setting 45-65 Hz).
	Circuit breaker or fuse in the AC-in input is open as a result of overload.	Remove overload or short circuit on AC-out-1 or AC-out-2, and reset fuse/breaker.
	The battery fuse has blown.	Replace the battery fuse.
	The distortion or the AC input voltage is too large (generally generator supply).	Turn the settings WeakAC and dynamic current limiter on.
The charger does not operate. 'Bulk Protection' shown.	MultiPlus-II GX is in 'Bulk protection' mode thus, the maximum bulk charging time of 10 hours is exceeded. Such a long charging time could indicate a system error (e.g. a battery cell short-circuit).	Check your batteries. NOTE: You can reset the error mode by switching off and back on the MultiPlus-II GX. The standard MultiPlus-II GX factory setting of the 'Bulk protection' mode is switched on. The 'Bulk protection' mode can be switched off with help of VEConfigure only.
The battery is not completely charged.	Charging current excessively high, causing premature absorption phase.	Set the charging current to a level between 0.1 and 0.2 times the battery capacity.
	Poor battery connection.	Check the battery connections.
	The absorption voltage has been set to an incorrect level (too low).	Set the absorption voltage to the correct level.

Problem	Cause	Solution
	The float voltage has been set to an incorrect level (too low).	Set the float voltage to the correct level.
	The available charging time is too short to fully charge the battery.	Select a longer charging time or higher charging current.
	The absorption time is too short. For adaptive charging this can be caused by an extremely high charging current with respect to battery capacity, so that bulk time is insufficient.	Reduce the charging current or select the 'fixed' charging characteristics.
The battery is overcharged.	The absorption voltage is set to an incorrect level (too high).	Set the absorption voltage to the correct level.
	Poor battery connection.	Check the battery connections.
	The float voltage is set to an incorrect level (too high).	Set the float voltage to the correct level.
	Poor battery condition.	Replace the battery.
	The battery temperature is too high (due to poor ventilation, excessively high environmental temperature, or excessively high charging current).	Improve ventilation, install batteries in a cooler environment, reduce the charging current, <b>and connect the temperature sensor.</b>
The charging current drops to 0 as soon as the absorption phase initiates.	Defective battery temperature sensor	Disconnect the temperature sensor plug in the MultiPlus-II GX. If charging functions correctly after approximately 1 minute, the temperature sensor should be replaced.
	The battery is over-heated (+50°C)	Install the battery in a cooler environment
		Reduce the charging current
		Check whether one of the battery cells has an internal short circuit

## 6.9 OPERATING TIME

### 6.9.1 Capacity

The runtime of the ECO Power Pack 60k is limited by the battery capacity, which is approximately 60000Wh. This means that a 5000W load could be run continuously for 12 hours, a 100W load for 600 hours, and so on.

### 6.9.2 Expected AC operating time.

As many types of work involving power tools do not involve continuous running of tools, a 'duty cycle' should be applied to estimate how long the ECO Power Pack 60k will last. For example:

- 100% duty cycle indicates that the load is running continuously (e.g., a compressor or floodlight)
- 40% duty cycle represents an intensive working pattern with a power tool such as a grinder or a drill.
- 20% duty cycle represents a normal working pattern for a range of power tools.
- 5% duty cycle represents sporadic use (around 3 minutes per hour)

The operating time also depends on the power of the tools being used: a higher power load will lead to a shorter battery runtime. For example:

- 1500W represents a large power tool such as a breaker or large circular saw.
- 600W represents a medium handheld power tool such as a grinder, jigsaw, or impact wrench.
- 150W represents a small handheld power tool such as a needle gun.
- 50W represents an efficient LED lighting system.

The table below gives the expected running time for each combination of these loads with 100% duty cycle.

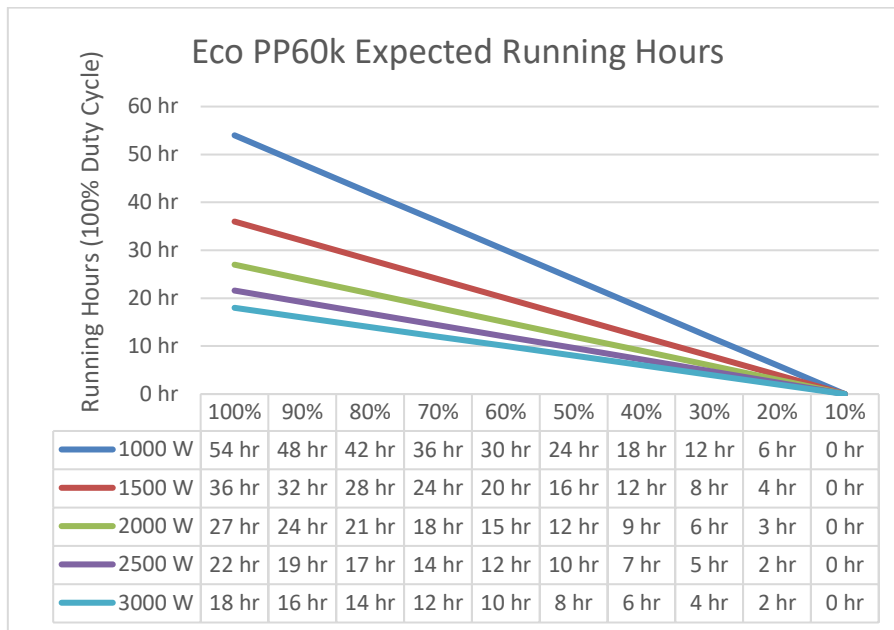

### 6.9.3 Strategies for increasing operating time.

The operating time between charges can be extended using the following strategies:

- Make sure the ECO Power Pack 60k is fully charged before use.
- Turn off the switch of the ECO Power Pack 60k when not in use (the internal battery will slowly drain, even when no load is connected)
- Use low-power tools and appliances where possible, e.g., LED lighting instead of incandescent lights.

## 7 Service and maintenance



### **WARNING**



**This product generates voltages which can cause serious injury or death if proper precautions are not taken, or if used improperly.**

**Disassembly and/or maintenance as described in this user manual should only be attempted by competent personnel who have read and understood the instructions in this manual.**

**If any other maintenance is required which is not prescribed here, the ECO Power Pack 60k should be returned to Light Green Power or approved distributor.**

**DO NOT attempt any repairs, maintenance, or modifications. Such activities are potentially hazardous and can result in serious injury or death and may result in a void warranty.**

**DO NOT attempt to maintain or repair damaged or malfunctioning equipment – the ECO Power Pack 60k should be returned to the distributor.**



---

## 8 Storage

Unlike conventional gasoline or diesel generators, the ECO Power Pack 60k does not require special storage preparations or regular cleaning and servicing. However, observing the following instructions will maximize the service life of the ECO Power Pack 60k.

### 8.1 BEFORE STORAGE

- Fully charge the ECO Power Pack 60k before placing into storage to avoid damage to the ECO Power Pack 60k through excessive battery depletion (remembering the maximum re-charge interval of 1 month)
- Ensure that the ECO Power Pack 60k is turned off before storing to avoid battery depletion.

### 8.2 STORAGE PRECAUTIONS

- Store the ECO Power Pack 60k in a dry place away from sources of moisture.
- Store the ECO Power Pack 60k at room temperature where possible, and always within a temperature range of 0-40°C.
- If the ECO Power Pack 60k is in long term storage, fully discharge and recharge the ECO Power Pack 60k once every 2 months to avoid damage caused by excessive battery depletion.

### 8.3 REMOVAL FROM STORAGE

- On removing the ECO Power Pack 60k from storage, fully charge the ECO Power Pack 60k for at least 2 hours using the supplied mains charger.

## 9 MAINTENANCE

### 9.1 CLEANING

 **CAUTION**

Make sure that the inlet and outlet vents are clean and free of obstructions when cleaning the machine.

Make sure that all moving parts are clean and free of dirt and debris to prevent malfunction of the machine.

All hire machines will be cleaned on return to the LGP depot.

When you clean the machine on site, remove all external power cables.

Wipe over the machine surfaces with lint free cloth and a mild detergent solution.

Never wash the machine with a power washer or high-pressure hose.

### 9.2 INSPECTION

Do a thorough inspection of the machine and its component parts on a regular basis.

#### 9.2.1 Decals and Labels

Examine all chassis mounted decals and labels for damage.

The decals and labels provide important operating instructions and warn of dangers and hazards.

Replace any missing or hard-to-read labels.

Spares are available from LGP.

## 10 Options

Not applicable to the Eco Power Pack 60K at the time of writing.

## 11 Troubleshooting

<b>Problem</b>	<b>Solution</b>
<b>When I switch the power on, the screen does not turn on</b>	The ECO Power Pack 60k needs to be charged. This will require a DC recovery charge to be carried out by LGP.
<b>When using the ECO Power Pack 60k, the screen indicates 'low battery'</b>	The ECO Power Pack 60k needs to be charged. Plug the ECO Power Pack 60k into the supplied mains charger.
<b>When using the ECO Power Pack 60k, the screen indicates 'no comms'</b>	The ECO Power Pack 60k needs to be recovery charged, contact LGP.
<b>When using the ECO Power Pack 60k, the power turns off and an audible 'beep' warning is heard</b>	The ECO Power Pack 60k is too hot. Switch off, unplug it, and leave it to cool. If possible, move to a cooler area.  If problem persists, the inlet filters may need cleaning – see maintenance section.
<b>When I plug in the mains charger, the screen does not light</b>	First, verify that front panel switch is in the 'on' position.  Then verify that the mains supply to the charger is active, and that the charger is not damaged. If the problem persists, contact the distributor.
<b>My AC load (e.g., power tool) will not start, despite other AC loads working</b>	It may be that the power tool you are attempting to use is not suitable for use with the ECO Power Pack 60k. Try using an alternative tool with a lower rated power. Power tools with large electric motors can require surges of power on start-up up to 5 times greater than their rated power.
<b>The ECO Power Pack 60k is depleted too quickly</b>	See the 'AC operation' section for strategies to extend operating time.
<b>My AC load (e.g., power tool) keeps cutting out while running</b>	If you are using several appliances at once, try using loads one at a time. If the problem persists, try using a load with a lower rated power.